

TRAFFIC SIGNALS

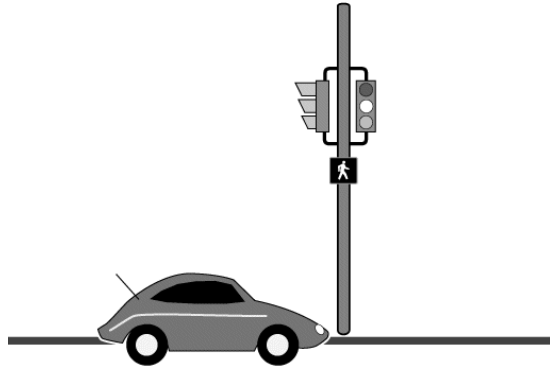

Each year, the County receives many inquiries concerning the operation of traffic signals within the County. A better understanding of the function of traffic signals can improve driving habits by reducing speeding and associated traffic accidents. The more drivers know about the operation of traffic signals the less they will be frustrated when waiting for a signal to change.

WHY ARE TRAFFIC SIGNALS NEEDED?

As traffic volumes increase beyond the capability of lesser controls such as a four-way stop, it may be necessary to install a traffic signal. Before installing a traffic signal at an

intersection, established minimum criteria must be satisfied. A review includes:

- ✓ The amount of vehicular and pedestrian traffic;
- ✓ The need to provide interruption to the major flow for side street vehicles and pedestrians;
- ✓ Special conditions such as hills and curves;
- ✓ The collision history of the intersection; and
- ✓ The proximity of schools.

ARE TRAFFIC SIGNALS THE ANSWER TO SOLVING TRAFFIC PROBLEMS?

Advantages of Traffic Signals

Signals offer maximum control at intersections. The primary function of any traffic signal is to assign right of way to conflicting movements of traffic at an intersection. This is done by permitting conflicting streams of traffic to share the same intersection by means of time separation.

By alternately assigning right of way to various traffic movements, signals provide for the orderly movement of conflicting flows. They may interrupt extremely heavy flows to permit the

crossing of minor movements that could not otherwise move safely through an intersection.

When properly timed, a traffic signal increases the traffic handling capacity of an intersection, and when installed under conditions that justify its use, a signal is a valuable device for improving the safety and efficiency of pedestrian, bicycle, and vehicular traffic. In particular, signals may reduce certain types of accidents, most notably right-angle (broadside) collisions.

Disadvantages of Traffic Signals

While many people realize that traffic signals can reduce the number of right-angle collisions at an intersection, few realize that signals can also cause a significant increase in rear-end collisions.

Installation of a traffic signal can lead to an increase in rear-end collisions, but there is normally a decrease in the more severe right-angle accidents; however, when there is no right-angle accident problem at an intersection and a signal is not needed for traffic control, there is no safety benefit and the installation of a traffic signal can actually cause a deterioration in the overall safety at the intersection.

TRAFFIC SIGNALS

Traffic signals are not a cure-all for traffic problems. The primary goal of the traffic engineer is to attain the safest and most efficient overall traffic flow possible. In addition to an increase in accident frequency, unjustified traffic signals can also cause excessive delay, disobedience of signals, and diversion of traffic to residential streets.

TRAFFIC SIGNAL EQUIPMENT

Traffic signals are more costly than is commonly realized, even though they represent a sound public investment when justified. A modern signal can cost up to \$150,000. This amount pays for:

- ✓ A Traffic Signal Controller
- ✓ Signal Heads
- ✓ Vehicle Detectors
- ✓ Signal Poles and Supports

The controller is the signal's brain. It consists of electrical or computer controls that operate the selection and timing of traffic movements in accordance with the varying demands of traffic as registered with the controller unit by detectors.

Signal faces are part of a signal head provided for controlling traffic in

a single direction and consisting of one or more signal sections. These usually include solid red, yellow, and green lights and sometimes red, yellow, and green turn arrow lights as well. The signal head can contain one or more signal faces.

Detectors are devices for indicating the passage or presence of vehicles. In the past, these consisted of wire

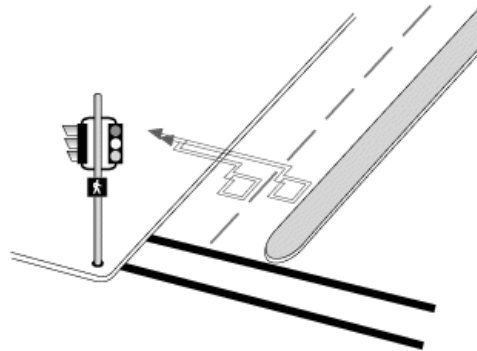

loops placed in the pavement at intersections. Today, video cameras are used to detect vehicles to change the operation of the signal to serve the heaviest traffic movements.

REQUESTS AND INQUIRIES

If you have questions, requests, or suggestions concerning traffic signals, please call the Transportation Department at: **(805) 654-2049** or through the "Contact Us" link at: <http://www.countyofventura.org>

Rev. 2-26-08



**Public Works Agency
Transportation Department**
800 S. Victoria Avenue
Ventura CA 93009-1620